

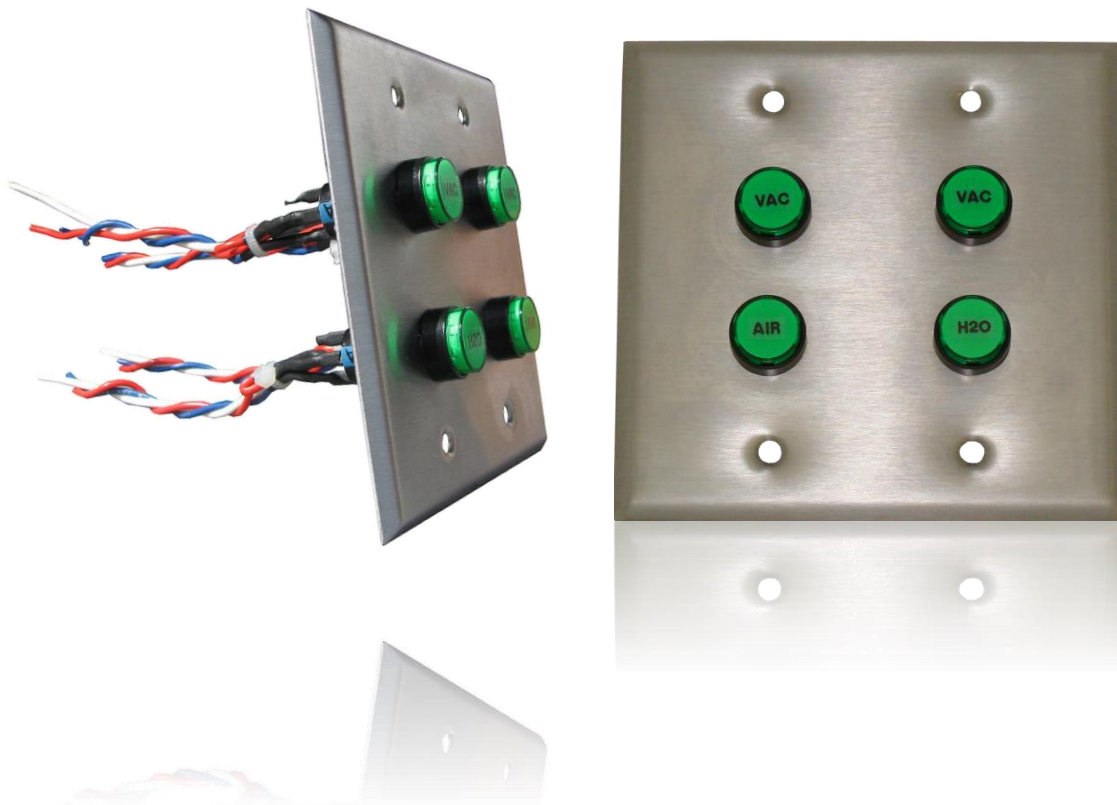

24 Volt Remote Control Panel

2017 USER MANUAL/Installation Instructions



1953 W. Gulf To Lake Hwy, Lecanto, FL 34461

Toll Free: 800-240-5677 FAX: 352-513-4801

TABLE OF CONTENTS

Cover	1
Congratulations	2
Customer support	3
Warranty Policy	4
Safety	5
Model breakdown	6
Specifications	7
Schematics	8
Installation	9
Operation	11

Congratulations!

On the purchase of your Sierra Dental Products 24 Volt Remote Control Panel. This Remote is universal for all types of vacuums, compressors, water security systems & any other dental equipment with 24 volt control. They can be customized to your specific needs. Sierra 24 Volt Remote Control Panel will allow you to easily operate any piece of equipment at the touch of a button from the inside of your practice/clinic.

We are certain you will love your new product!

If you are not satisfied 100% with this products please reach out and let us know, *we are successful because of your FEEDBACK!*

800-240-5677

Email: sierradentalproducts@outlook.com

CUSTOMER SUPPORT

“We are happy to help you with any questions or concerns you may have about your dental equipment”

Contact Us 24/7 We're here to help!

NAME	ROLE	NUMBER
Karen Bennett	Owner	(352) 527-1975
Chuck Bennett	Owner/Engineer	(352) 527-1975
David Rolerad	Owner/Quality control	(352) 527-1975
Matthew Ball	Ops Manager	(352) 527-1975
Aaron Ball	Marketing/Sales	(352) 527-1975
Toll Free	24/7	(800) 240-5677

SierraDentalProducts@outlook.com

DentalVacuums.com



Sierra Dental Products LLC

1953 W. Gulf to Lake Hwy

Lecanto, FL 34461

WARRANTY POLICY

Sierra Dental Products Limited Warranty

Warranty for the 24 volt remote control panel is limited to the original purchaser of the unit. Sierra Dental Products is only obligated under this warranty to the repair or replacement of defective parts or materials. The defect(s) must be reported to Sierra Dental Products within the valid warranty period.

Sierra Dental Products will examine the product to determine if the parts are defective. Products that have been abused, neglected, or damaged by being improperly installed/maintained are not covered by this warranty. We are not responsible for work performed on the unit by any unauthorized service agents. Sierra dental products LLC is not responsible for direct or indirect damages or loss caused by this unit.

Warranty Period

Warranty is valid only with the return of the warranty card within 30 days of purchase for a period of **1 year**

Warranty Service and Return Policy

To obtain warranty service, product must be returned to Sierra Dental Products for examination at the purchaser's expense. All returns must be authorized and a return material authorization (RMA#) number must be obtained from Sierra Dental Products. Returned units must be properly packaged for shipping. We are not responsible for shipping damages or shipping charges. Sierra Dental Products will, at their discretion, repair or replace defective parts.

****Note** there is a 25% re-stocking fee on all returns.**

SAFETY

Use of the Sierra Low Voltage Remote Control Panel not in compliance with the instructions specified in this manual may result in permanent failure of the remote.

WARNING

To prevent fire or electrical shock, do not expose this unit to rain or moisture, excessive heat or improper ventilation.

ATTENTION USERS



Alerts users of important operating and maintenance instructions. Read carefully to avoid any problems



Warns users of a potentially hot surface, and a danger of burns



Warns users that uninsulated voltage is present and can cause electric shock

MODEL BREAKDOWN

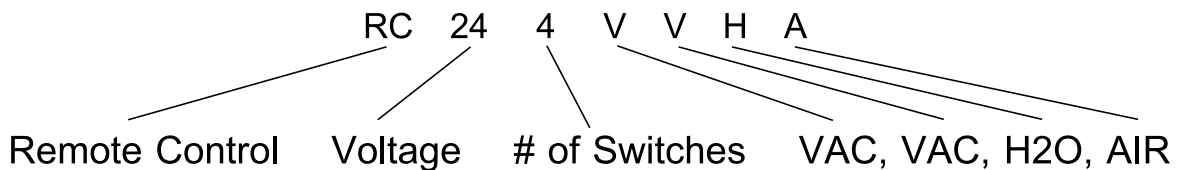

There are many variations that will dictate the actual model. All of the control panels can be built specific to your needs, based on the number of switches & what equipment you plan to use with each available switch. The Model & Serial number can be found on the backside of the panel.

SPECIFICATIONS

BRAND	I.D.E.C.
SERIES	A6
Mounting size (mm)	16 mm
Operation	Maintained
Contacts	SPDT
Lens/Button shape	Round extended
Lens/Button color	Green
Lamp type	LED
Nominal lamp voltage	24 V AC
Illumination circuit	Full voltage
Bezel	Plastic round
Full shroud	No
Current	3 Amps
IEC Rating	IP40
Depth behind panel	1.22"
Operator size (mm)	18 mm
Dimensions	4.5" x 4.5" x 2"
Material	Stainless steel
Fits	Standard 2 gang box
Comments	Fixed contacts. LED included. Built-in limiting resistor & reverse polarity protection diode.

SCHEMATICS

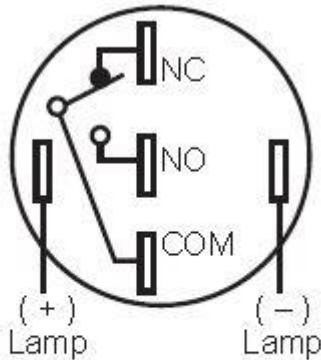

**SPDT Contact
(Single-pole/Double Throw)**

Pushbuttons, Ø 5/8" (16mm)

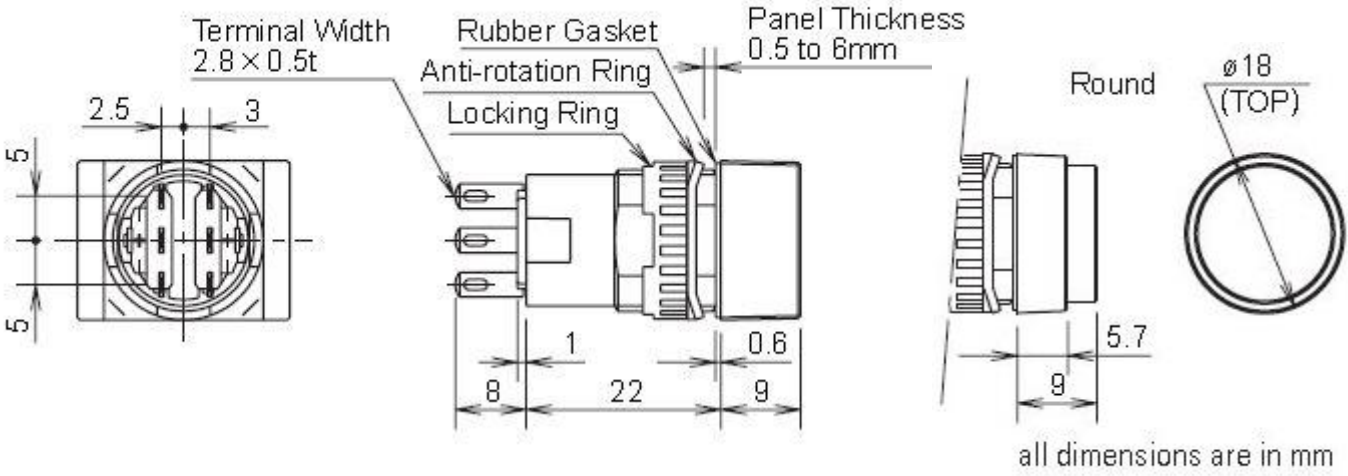

INSTALLATION



24 volt remote control panels can control up to 4 different compatible devices.

Ensure that all equipment is NOT electrically energized during installation

Wherever you plan to mount the 24 volt remote switch, make sure that you have already ran low voltage wire from all equipment. Unless this remote is replacing an older version or different type of 24 volt remote.

Decipher which wires correspond with the equipment and mark these. You can do this by going into the mechanical room and disconnecting all of the remote wires from each controller. Short only one set of remote wires together. Now go back to where the panel will be mounted and using a multi-meter, ohm out each set of wires until one completely ohms out. That will be the set of wires you shorted together. Continue this process until each set has a matching piece of equipment.

Contact technical support with any concerns regarding installation

800-240-5677

INSTALLATION



-Each pushbutton has a specific label for certain equipment, you must match the pushbuttons to each piece of equipment.

-Contact Manufacturer of equipment to be controlled for remote wire color coding

-There are (3) wires for each pushbutton: Red, White, & Blue.

-The red and blue are going to be your switch legs.

-The White wire is for illumination.

-All equipment has slight variation. This means that you will have to connect the wires to the equipment's corresponding wires and test each circuit to ensure that the light turns on & off with the pushbutton & does not remain on. If the light remains on when the equipment is off, switch the red & blue wires.

-Once all equipment is successfully controlled by the new remote, neatly tuck all wires inside of the electrical box. Be sure that no wires can short, This can cause the remote to function improperly. It can also cause fire & electric shock!

-Tighten all (4) screws provided and test once more.

Contact technical support with any concerns regarding installation

800-240-5677

OPERATION



Operation is very simple. To operate the equipment connected to the 24 volt remote control panel you simply press the button that corresponds with the desired piece of equipment. A green LED will inform you of power.

Notice in the image above how the LED easily shows the difference between on & off

-Pushing the button on will turn the equipment on

-Pushing the button once more will shut the equipment off

If you are seeing illumination & the corresponding equipment is not turning on, ensure that the remote configuration for that piece of equipment is correct. Configuration changes slightly between brands, Contact the manufacturer of your equipment for correct wiring & configuration.